

**(R) Describing and Measuring the Driver's Field of View**

**Foreword**—This Document has also changed to comply with the new SAE Technical Standards Board Format. Definitions has been changed to Section 3. All other Section numbers have changed.

**TABLE OF CONTENTS**

1	Scope .....	2
2	References .....	2
2.1	Applicable Publications .....	2
3.	Definitions.....	2
4.	Measuring Direct Field of View .....	5
4.1	Direct Field for an Individual Driver .....	5
4.2	Direct Field for a Group of Drivers.....	7
4.3	Method for Approximating Direct field of View Through Windows.....	10
5	Measuring Indirect Field of View .....	10
5.1	Field of View for an Individual Driver .....	10
5.2	Field of View for a Group of Drivers .....	11
5.3	Field of View Using Neck Pivot Points Defined in SAE J941 .....	12
6	Obstructions .....	12
6.1	Obstruction in Direct Field as Seen by an Individual Driver .....	12
6.2	Obstructions in the Direct Field as Seen by a Group of Drivers.....	13
6.3	Determining the Areas on the Display and Control Surfaces Which are not Obstructed .....	14
6.4	Obstructions in the Indirect Field .....	14
Appendix A Developing V and P Points.....		15
Appendix B Approximating the Indirect Field of View Using "P" Points Defined in SAE J941 .....		17
Appendix C Approximating the Obstruction Angle from A-Pillars .....		18
Appendix D Approximating the Visible Areas on Control and Display Surfaces .....		19

SAE Technical Standards Board Rules provide that: "This report is published by SAE to advance the state of technical and engineering sciences. The use of this report is entirely voluntary, and its applicability and suitability for any particular use, including any patent infringement arising therefrom, is the sole responsibility of the user."

SAE reviews each technical report at least every five years at which time it may be reaffirmed, revised, or cancelled. SAE invites your written comments and suggestions.

Copyright ©2003 Society of Automotive Engineers, Inc.

All rights reserved. No part of this publication may be reproduced, stored in a retrieval system or transmitted, in any form or by any means, electronic, mechanical, photocopying, recording, or otherwise, without the prior written permission of SAE.

**TO PLACE A DOCUMENT ORDER:**

Tel: 877-606-7323 (inside USA and Canada)  
 Tel: 724-776-4970 (outside USA)  
 Fax: 724-776-0790  
 Email: [custsvc@sae.org](mailto:custsvc@sae.org)  
<http://www.sae.org>

**SAE WEB ADDRESS:**

1. **Scope**—This SAE Recommended Practice establishes methods for describing and measuring the driver's field of view. The document describes three methods for measuring the direct and indirect fields of view and the extent of obstructions within those fields. The first method uses any single pair of eye points to determine the fields or obstructions that would be seen by an individual driver. The second method uses the SAE Eyellipses defined in SAE J941 to determine the largest fields or obstructions that would be seen for a given percentage of the driving population. The third method uses specific eye points defined in SAE J941 to measure the extent of a specific field of view or obstruction for which those points were developed.

2. **References**

2.1 **Applicable Publications**—The following publications form a part of this specification to the extent specified herein. Unless otherwise indicated, the latest issue of SAE publications shall apply.

2.1.1 SAE PUBLICATIONS—Available from SAE, 400 Commonwealth Drive, Warrendale, PA 15096-0001.

SAE J264—Vision Glossary

SAE J941—Motor Vehicle Drivers' Eye Locations

SAE J985—Vision Factors Considerations in Rear View Mirror Design

3. **Definitions**

3.1 **Vision Origin Points**

3.1.1 EYE POINT (E POINT) (FIGURE 1)—Point representing the location of the eye and from which sight lines may originate. The left and right eye points are 65.0 mm apart.

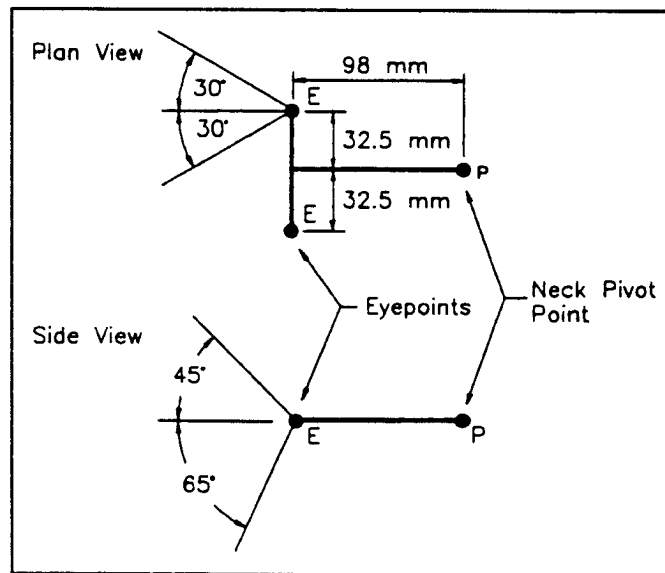

FIGURE 1—EYES MAY ROTATE ABOUT THE EYE POINTS (E POINTS) A MAXIMUM OF 30 DEGREES LEFT AND RIGHT, 45 DEGREES UP AND 65 DEGREES DOWN

3.1.2 NECK PIVOT POINT (P POINT) (FIGURE 1)—A point about which the driver's head turns on a horizontal plane. It is located 98 mm rearward and midway between the left and right eye points. (Appendix A)

3.1.3 VISION POINT (V POINT)—A point developed and used for defining and measuring specific direct field of view requirements. (Appendix A)

3.2 **Sight Line**—A line representing the driver's line of sight from an eye point or a V Point to a target point or at a given angle.

3.3 **Eye Rotation**

3.3.1 MAXIMUM EYE ROTATION (FIGURE 1)—The eye may rotate a maximum of 30 degrees left, 30 degrees right, 45 degrees up, and 65 degrees down from straight ahead.

3.3.2 EASY EYE ROTATION—The eye may rotate easily 15 degrees left, 15 degrees right, 15 degrees up, and 15 degrees down from straight ahead.

3.4 **Head Turn**

3.4.1 MAXIMUM HEAD TURN (FIGURE 2)—The driver's head may turn about a vertical axis a maximum of 60 degrees to the left or to the right from the straight ahead position.

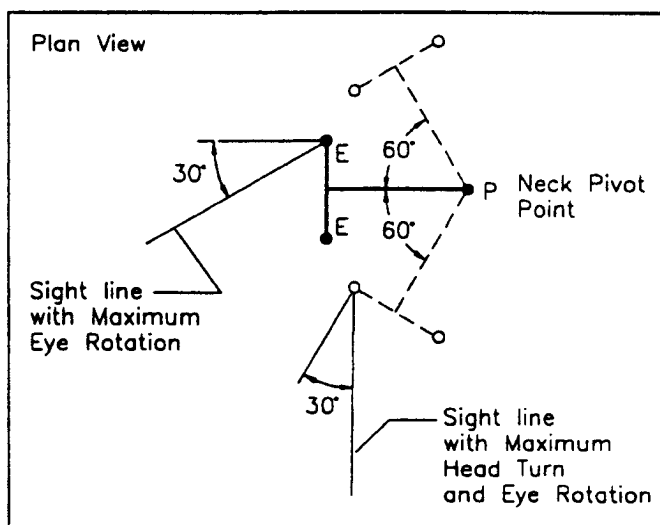

FIGURE 2—THE SIGHT LINES AND EYE POINTS (E POINTS) MAY ROTATE ABOUT THE NECK PIVOT POINT (P POINT) A MAXIMUM OF 60 DEGREES LEFT OR RIGHT

3.4.2 EASY HEAD TURN—The driver's head may easily turn about a vertical axis 45 degrees to the left or to the right from the straight ahead position.

**3.5 Indirect Vision Device**—Any device used by a driver to view a field. Examples are mirrors and video systems.

**3.6 Field of View**—The solid angle defined by sight lines originating from one or more eye points.

3.6.1 DIRECT FIELD OF VIEW—The field of view seen without the aid of any devices.

3.6.2 INDIRECT FIELD OF VIEW—The field of view seen with the use of devices.

3.6.3 MONOCULAR FIELD OF VIEW (FIGURE 3)—The field of view that can be seen by one eye.

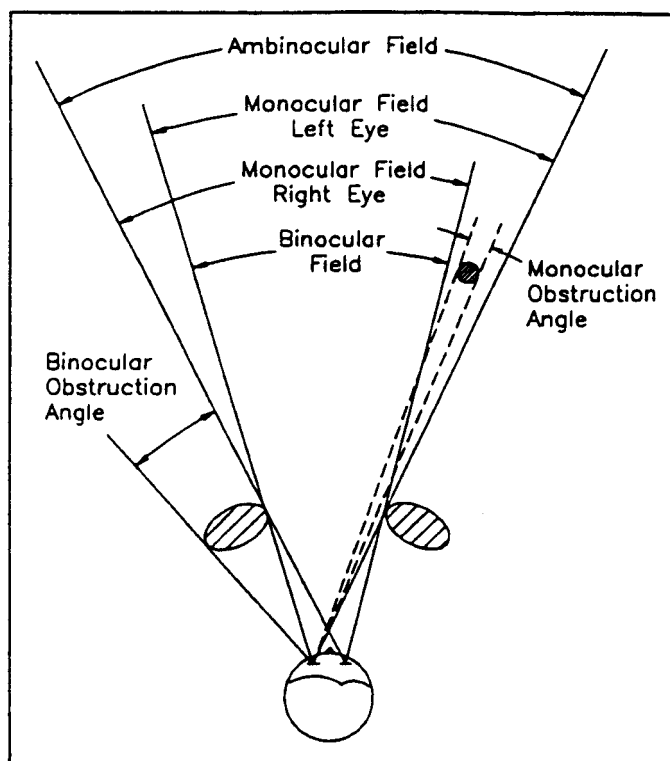

FIGURE 3—DIRECT HORIZONTAL FIELD OF VIEW. THE BINOCULAR OBSTRUCTION IS SEEN BY BOTH EYES. THE MONOCULAR OBSTRUCTION IS SEEN ONLY BY THE LEFT EYE.

3.6.4 BINOCULAR FIELD OF VIEW (FIGURE 3)—The field of view that can be seen by both eyes simultaneously.

3.6.5 AMBINOCULAR FIELD OF VIEW (FIGURE 3)—The total field of view that can be seen by both eyes separately. This includes the binocular field as well as the monocular field visible to the right eye but not the left eye and vice versa.

3.6.6 RANGE OF FIELD OF VIEW (FIGURE 4)—The sum of the angular fields of view to the right and left (or up and down) which can be seen by an individual driver or by the percent of drivers specified by an Eyellipse which is used. Although the same percent of drivers will see the field to the left and the field to the right (or up and down), not all the same drivers will be included in both groups.

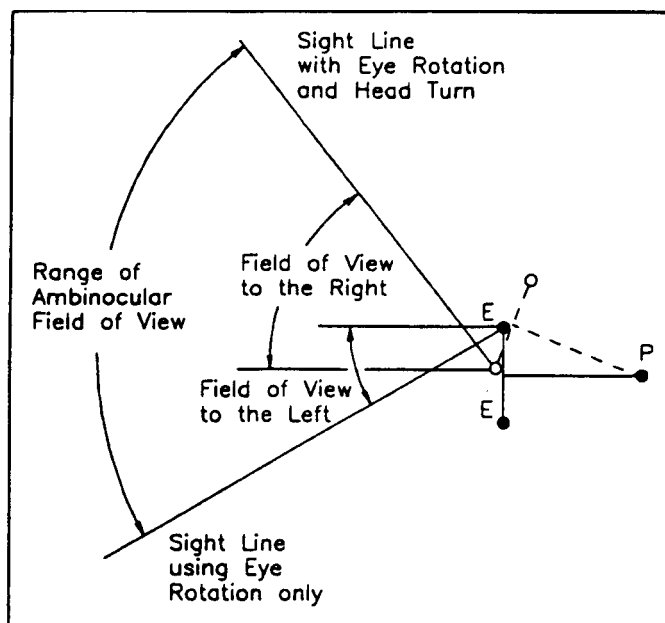

FIGURE 4—RANGE OF DIRECT AMBINOCULAR FIELD OF VIEW IS THE SUM OF THE FIELD TO THE LEFT AND THAT TO THE RIGHT

3.6.7 PERIPHERAL FIELD OF VIEW—The field of view that extends a maximum of 90 degrees in the temporal direction.

### 3.7 Obstruction

3.7.1 BINOCULAR OBSTRUCTION (FIGURE 3)—Any object within the binocular view which creates an area behind it which cannot be seen simultaneously by the left and right eyes.

3.7.2 MONOCULAR OBSTRUCTION (FIGURE 3)—Any object visible to only one eye which creates an area behind it which cannot be seen by that eye.

4. **Measuring Direct Field of View**—The direct field of view is measured using ambinocular vision, so any point or angle is deemed visible if at least one of the eyes can see it. Therefore, when measuring an angular field limited by an aperture (e.g., through a window), the largest angular field at any point along the aperture is that seen by the eye point farthest from the point on the aperture. The largest field to the left is found using the right eye point and the largest field to the right is found using the left eye point.

When determining whether a specific point or angle can be seen within a field that is not limited by an aperture, the eye point closest to the point or angle will view the point or angle with the smallest head turn and/or eye rotation. Therefore, the right eye point should be used to view a point to the right and the left eye point used to view a point to the left.

4.1 **Direct Field for an Individual Driver**—If the following procedure is performed for points at the left and right limits of the field, the horizontal angle between the two sight lines is the driver's direct ambinocular field of view. The field may be limited by an aperture or by the limits of eye rotation. Likewise, the vertical field of view may be found using the top and bottom field limits.

4.1.1 SELECT THE EYE POINT—If the field is limited by an aperture, use the eye point farther from the point on the aperture under consideration. (Figure 5)

If the field is not limited by an aperture, use the eye point closer to the point or angle to be viewed. (Figure 6)

4.1.2 ROTATE THE SIGHT LINE ABOUT THE EYE POINT (FIGURES 5 AND 6)—Rotate the sight line about the eye point until it reaches the specified point or angle but not farther than allowed by maximum horizontal and vertical eye rotation. If the sight line does not reach the point or angle, then it is not visible with eye rotation only.

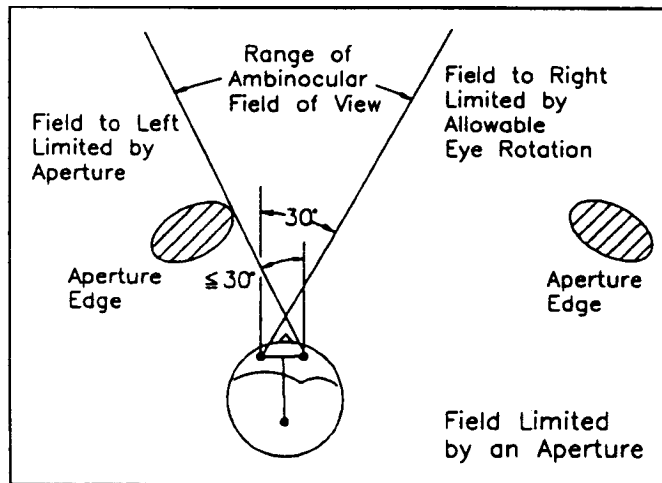

FIGURE 5—RANGE OF HORIZONTAL AMBINOCULAR FIELD OF VIEW FOR AN INDIVIDUAL DRIVER WITH EYE ROTATION ONLY. IN THIS EXAMPLE, THE FIELD TO THE LEFT IS LIMITED BY THE APERTURE AND THE FIELD TO THE RIGHT IS LIMITED BY ALLOWABLE EYE ROTATION.

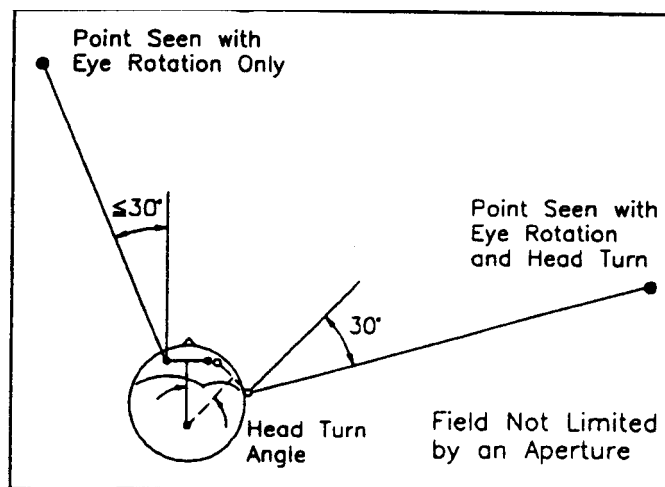

FIGURE 6—INDIVIDUAL DRIVER VIEWING POINTS WITHIN A FIELD WHICH IS NOT LIMITED BY AN APERTURE. IN THIS EXAMPLE, THE POINT ON THE LEFT IS SEEN WITH EYE ROTATION ONLY AND THAT ON THE RIGHT IS SEEN USING EYE ROTATION AND HEAD TURN.

- 4.1.3 **FIELD OF VIEW WITH EYE ROTATION ONLY**—The field of view with eye rotation only is defined using the horizontal and vertical angles of the sight line from 4.1.2 or the point where the sight line intersects a target.
- 4.1.4 **ROTATE THE SIGHT LINE ABOUT THE NECK PIVOT POINT (FIGURES 6 AND 7)**—If the sight line from 4.1.2 does not pass through the specified point or does not reach the specified angle, then rotate it about the neck pivot point until it either reaches the point or angle or reaches maximum head turn. If the sight line does not reach the point or angle, then it is not visible within the limits of maximum eye rotation and head turn.

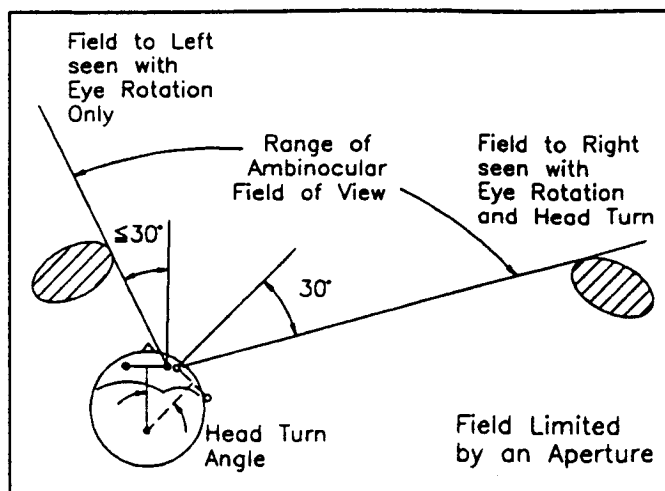

FIGURE 7—RANGE OF HORIZONTAL AMBINOCULAR FIELD OF VIEW THROUGH AN APERTURE FOR AN INDIVIDUAL DRIVER. IN THIS EXAMPLE, THE FIELD TO THE LEFT IS SEEN WITH EYE ROTATION ONLY AND THAT TO THE RIGHT IS SEEN WITH EYE ROTATION AND HEAD TURN.

- 4.1.5 **FIELD OF VIEW WITH EYE ROTATION AND HEAD TURN**—The field of view with eye rotation and head turn is defined using the horizontal and vertical angles of the sight line from 4.1.4 or the point where the sight line intersects a target.
- 4.2 Direct Field for a Group of Drivers**—The Eyellipses may be used to determine the largest direct field of view which will be seen by everyone within a selected group of drivers. The selected group is determined by the Eyellipse chosen. If the 95th percentile Eyellipse is used in this procedure, 95% of drivers will view at least the calculated field.
- 4.2.1 **FIELD FOR ANY ANGLE OR POINT**—Direct field of view is defined using a plane which is tangent to an Eyellipse and which either goes through the point of interest or is at the desired angle. The plane may be at any orientation relative to the coordinate system within the limits of maximum head turn and eye rotation. Because all the eye points of the selected group are on the ellipse side of that tangent plane, all drivers within the group will view at least the angle on the ellipse side of the plane.

If the tangent plane contains a point on an aperture and is tangent to the side of the Eyellipse closest to the aperture point, all drivers within the group would be able to see through the aperture at the angle of the plane. The largest field through the aperture would be defined using the Eyellipse farthest from the aperture point.

If the tangent plane contains a specified point in space and is tangent to the side of the Eyellipse farthest from the point, all drivers within the group would be able to see that point. The point will be seen with the least head turn and eye rotation if the Eyellipse closest to the specified point is used.

4.2.2 HORIZONTAL FIELD—The horizontal range of direct ambinocular field of view for the selected group of drivers is the horizontal angle between two vertical planes defined when the following procedure is performed for points at the left and right limits of the vision area. The limits may be those imposed by an aperture or by maximum eye rotation and head turn.

4.2.2.1 *Select the Proper Eyellipse*—If the field is limited by an aperture, use the Eyellipse farthest from the point on the aperture and construct the plane to the side of the Eyellipse closest to the point. (Figure 8)

If the field is not limited by an aperture, use the Eyellipse closest to the point or angle and construct the plane to the side of the Eyellipse farthest from the point or angle. (Figure 9)

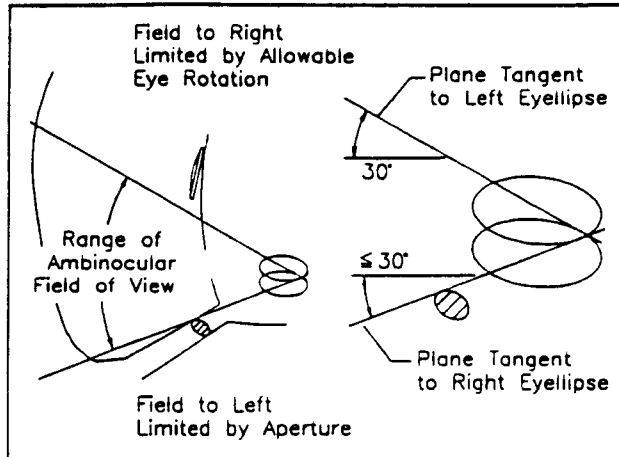

FIGURE 8—THE RANGE OF HORIZONTAL AMBINOCULAR FIELD OF VIEW FOR A GROUP OF DRIVERS WITH EYE ROTATION ONLY IS THE ANGLE BETWEEN A VERTICAL PLANE TANGENT TO THE LEFT SIDE OF THE RIGHT EYELLIPSE AND ONE TANGENT TO THE RIGHT SIDE OF THE LEFT EYELLIPSE IN THIS EXAMPLE, THE FIELD TO LEFT IS LIMITED BY THE APERATURE AND THE FIELD TO THE RIGHT IS LIMITED BY EYE ROTATION.

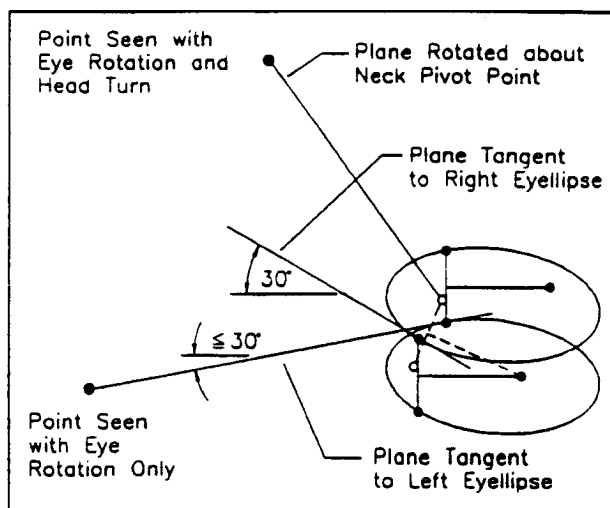

FIGURE 9—POINTS VISIBLE TO A GROUP OF DRIVERS WITHIN A FIELD NOT LIMITED BY AN APERTURE. IN THIS EXAMPLE, THE POINT ON THE LEFT IS SEEN WITH EYE ROTATION ONLY AND THAT TO THE RIGHT IS SEEN USING EYE ROTATION AND HEAD TURN.



- 4.2.2.2 *Define the Tangent Plane Within the Limits of Eye Rotation (Figures 8 and 9)*—Locate a vertical plane through the point or at the specified angle and tangent to the Eyellipse. If the angle of the plane, as measured from straight ahead, exceeds that allowed by maximum eye rotation, the specified point or angle is not visible. In this case, relocate the plane tangent to the Eyellipse at the angle allowed by maximum eye rotation.
- 4.2.2.3 *Field With Eye Rotation Only*—The field of view with eye rotation only is defined by the horizontal angle of the plane.
- 4.2.2.4 *Rotate the Plane Within the Limits of Head Turn (Figures 9 and 10)*—If the vertical plane from 4.2.2.2 does not pass through the specified point or reach the specified angle, it may be further rotated about a vertical axis through the neck pivot point until it does, but not farther than allowed by maximum head turn. If the plane does not reach the point or angle, then it is not visible within the limits of maximum eye rotation and head turn.

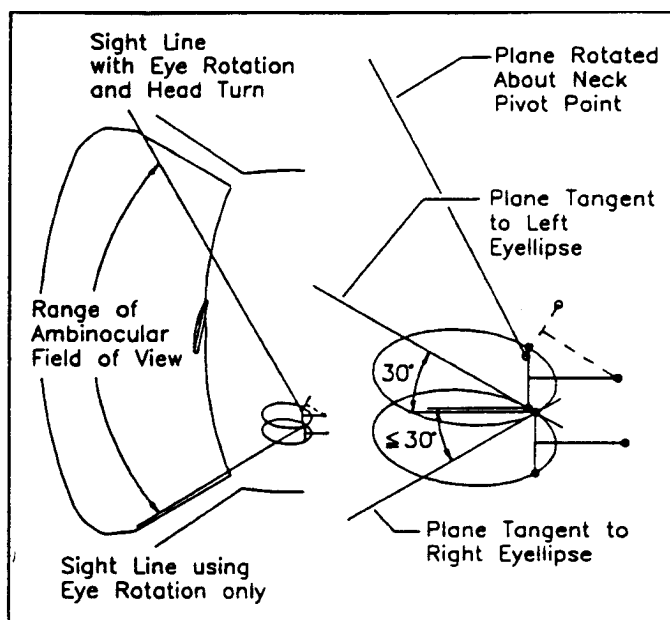

FIGURE 10—THE RANGE OF HORIZONTAL AMBINOCULAR FIELD OF VIEW FOR A GROUP OF DRIVERS USING EYE ROTATION AND HEAD TURN. IN THIS EXAMPLE, THE FIELD TO THE LEFT IS SEEN WITH EYE ROTATION ONLY AND THAT TO THE RIGHT IS SEEN WITH EYE ROTATION AND HEAD TURN.

- 4.2.2.5 *Field With Eye Rotation and Head Turn*—The field of view is defined by the horizontal angle of the plane.
- 4.2.3 **VERTICAL FIELD (FIGURE 11)**—The direct vertical field of the selected group of drivers is defined using planes tangent to the Eyellipse and perpendicular to a vertical plane along the longitudinal axis of the vehicle (the Y-Z plane). The selected group will view at least the field on the ellipse side of the tangent plane.

If the following procedure is performed for points at the top and bottom limits of the field, the vertical angle between the two planes defines the vertical range of the direct field of view. The limits of the field may either be those imposed by apertures or by maximum eye rotation.

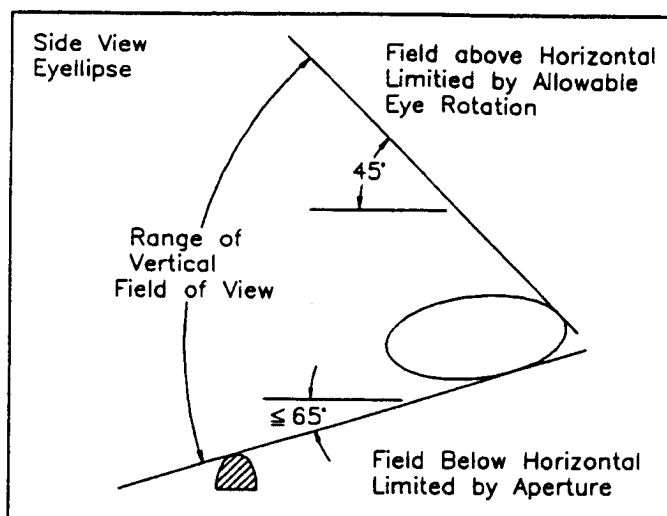

FIGURE 11—RANGE OF VERTICAL FIELD OF VIEW FOR A GROUP OF DRIVERS. IN THIS EXAMPLE, THE DOWNWARD FIELD IS LIMITED BY THE APERTURE AND THE UPWARD FIELD IS LIMITED BY ALLOWABLE EYE ROTATION.

- 4.2.3.1 *Define the Tangent Plane Within the Limits of Eye Rotation*—Locate a plane perpendicular to the Y-Z plane, through a specified point or at a specified angle and tangent to the top or bottom of the Eyellipse, whichever is closest to the point. If the plane is inclined upward or downward by an angle greater than allowed by maximum eye rotation, then the point or angle is not visible within the limits of maximum eye rotation.
- 4.2.3.2 *Field of View*—The field is defined by the angle by which the plane is inclined above or below a horizontal plane.
- 4.3 **Method for Approximating Direct Field of View Through Windows**—For the purpose of comparing the direct fields of view provided by a group of vehicles or windows of different sizes, the mid-Eyellipse centroid should be used as the most acceptable single eye point.
5. **Measuring Indirect Field of View**—The field of view of an indirect vision device (i.e., mirrors, cameras) is defined using ambinoocular vision. The fields may be described either using horizontal and vertical angles or areas seen on a specified target.
- 5.1 **Field of View for an Individual Driver**
- 5.1.1 **SELECT THE EYE POINT (FIGURE 12)**—Use the eye point farthest from any point on the display device and the point on the display farthest from that eye point.
- 5.1.2 **ROTATE THE SIGHT LINE WITHIN THE LIMITS OF ALLOWABLE EYE ROTATION (FIGURE 12)**—Rotate a sight line about the eye point until it either passes through the point on the display or reaches the angle allowed by maximum horizontal or vertical eye rotation.

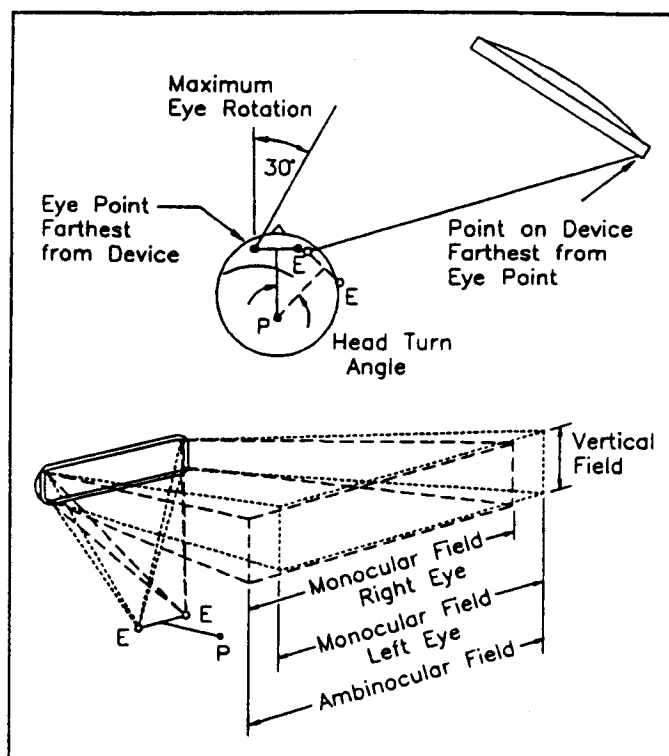

FIGURE 12—WHEN VIEWING THE INDIRECT VISION DEVICE, THE EYE POINT FARTHER FROM THE DEVICE IS ROTATED TO VIEW THE POINT ON THE DEVICE FARTHEST FROM THE EYE. THE FIELD OF VIEW IS MEASURED AMBINOCULARLY.

- 5.1.3 ROTATE THE SIGHT LINE WITHIN THE LIMITS OF ALLOWABLE HEAD TURN (FIGURE 12)—If the sight line from 5.1.2 does not pass through the display point, rotate it about the neck pivot point until it does, but not farther than allowed by maximum head turn.
- 5.1.4 TRACE SIGHT LINES THROUGH THE OPTICAL SYSTEM (FIGURE 12)—Trace sufficient sight lines from the left and right eye points through the optical system to define the field of view. The field may be defined using the horizontal and vertical angles of the sight lines or the points at which they intersect a target.

NOTE—For systems which use electronic sensors and display, the sight lines would be traced through the optical system from the sensor.

- 5.2 Field of View for a Group of Drivers**—The Eyellipses may be used to determine the largest indirect field of view through a device which may be seen by everyone within a selected group of drivers. The selected group is determined by the Eyellipse chosen. If the 95th percentile Eyellipse is used in this procedure, 95% of drivers will view at least the angle calculated or the area of the target defined.

The horizontal indirect ambinocular field for the group of drivers is the largest horizontal angle between two sight lines defined when the following procedure is performed for points at the left and right extremes of the vision device. Likewise the vertical field for the selected group of drivers is the largest vertical field between the two sight lines defined when the following procedure is performed for points at the top and bottom extremes of the vision device.

- 5.2.1 LOCATE THE EYE POINTS (FIGURE 13)—Define one eye point at the point on either Eyellipse which is farthest from any point on the indirect vision display. Locate the other eye point in the corresponding position on the opposite Eyellipse. Locate the neck pivot point for these eye points.

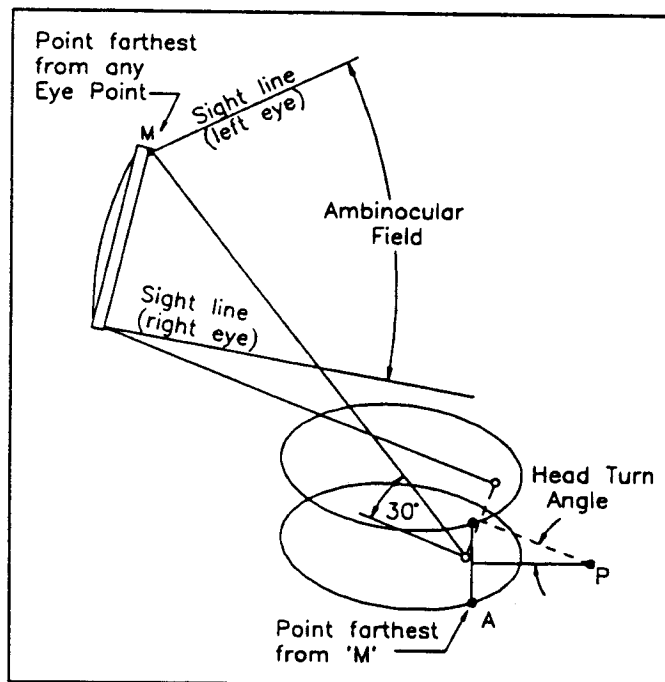

FIGURE 13—INDIRECT FIELD OF VIEW FOR A GROUP OF DRIVERS. ONE EYE POINT IS THE POINT ON THE EYELLIPSES (A) FARTHEST FROM ANY POINT ON THE DISPLAY (M). THE OTHER IS ON THE OPPOSITE ELLIPSE IN THE CORRESPONDING POSITION.

- 5.2.2 Rotate the eye points and calculate the field using the procedures outlined in 5.1.
- 5.3 **Field of View Using Neck Pivot Points Defined in SAE J941**—A method for approximating maximum field of view for a group of drivers using neck pivot points defined in SAE J941 is given in Appendix B.
6. **Obstructions**—Obstructions anywhere within the direct or indirect fields of view may be described by defining the horizontal or vertical obstruction angles or by defining areas on a specified target which are obstructed.
- 6.1 **Obstruction in Direct Field as Seen by an Individual Driver (Figure 14)**
- 6.1.1 SELECT THE EYE POINT—Use the right eye point for obstructions to the right and left eye point for those on the left.
- 6.1.2 ROTATE THE SIGHT LINE WITHIN THE LIMITS OF EYE ROTATION—Rotate a sight line from the selected eye point until it is tangent to a point on the outboard side of the obstruction, but not farther than allowed by maximum eye rotation.

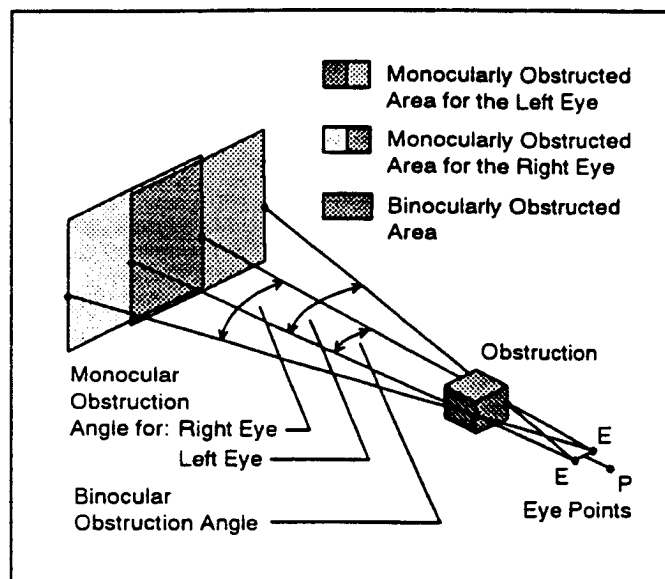

FIGURE 14—OBSTRUCTION ANGLES AND OBSTRUCTED AREAS SEEN BY AN INDIVIDUAL DRIVER

- 6.1.3 **ROTATE THE SIGHT LINE WITHIN THE LIMITS OF HEAD TURN**—If the sight line of 6.1.2 did not reach the outboard side of the obstruction, the eye points and sight line may be rotated about a vertical axis through the neck pivot point until the sight line reaches the outboard side of the obstruction but not farther than allowed by maximum head turn.
- 6.1.4 Define the obstructed angle or area in one of the following ways. (Figure 14)
- 6.1.4.1 *Monocular Obstruction Angle*—The monocular obstruction angle across any section through an obstruction is the angle between the sight lines from a single eye point to the left and right sides of the section.
- 6.1.4.2 *Binocular Obstruction Angle*—The horizontal binocular obstruction angle across any horizontal section through the obstruction is the angle between a sight line from the right eye tangent to the right side of the section and the sight line from the left eye tangent to the left side of the section. If these lines converge or are parallel, then no obstruction exists.
- 6.1.4.3 *Obstructed Area on a Plane*—The obstructed area on a plane is found for an eye point by locating points on the plane where sight lines tangent to the periphery of the obstruction intercept the plane. The area contained within these points is the monocularly obstructed area for that eye point. The section where the obstructed area from one eye point overlaps that from the other eye point is not seen by either eye and is binocularly obstructed.
- 6.2 **Obstructions in the Direct Field as Seen by a Group of Drivers**—The Eyellipses may be used to determine the largest obstruction angle which will be seen by anyone within a selected group of drivers. The selected group is determined by the Eyellipse chosen. If the 95th percentile Eyellipse is used in this procedure, 95% of drivers will have their vision obstructed by not more than the maximum obstruction angle calculated.

- 6.2.1 **MAXIMUM OBSTRUCTION ANGLE**—Because of the three-dimensional nature of obstructions, the obstruction profile will differ depending on the eye points selected. The only accurate method of finding the maximum obstruction is to calculate the obstruction angle for all points on the Eyellipse which may potentially result in the maximum obstruction. Eye points are located by selecting one point on the left or right Eyellipse and locating the corresponding point on the opposite Eyellipse. The neck pivot point is located for these eye points and the obstruction calculated using the procedure in 6.1.
- 6.2.2 **APPROXIMATING MAXIMUM OBSTRUCTION ANGLE**—To approximate maximum obstruction angle for a group of drivers, locate the point on the Eyellipses closest to the obstruction, the corresponding eye point on the opposite Eyellipse, and the neck pivot point. Calculate the obstruction angle using the procedure in 6.1.
- 6.2.3 **A-PILLAR OBSTRUCTION ANGLE**—A method for approximating the maximum obstruction angle from the A-Pillar is given in Appendix C.
- 6.3 Determining the Areas on the Display and Control Surfaces Which are Not Obstructed**—The Eyellipses may be used to determine the areas on a display surface which are visible to a selected group of drivers. The selected group is determined by the Eyellipse chosen. If the 95th percentile Eyellipse is used in this procedure, 95% of drivers will view at least this unobstructed area.
- 6.3.1 **UNOBSTRUCTED AREAS**—For a group of drivers, the unobstructed area is that area outside all the binocularly obstructed areas for all the eye points. To determine unobstructed areas, determine the binocularly obstructed areas on the display of interest using the procedure in 6.1 for a sufficient number of eye points on the Eyellipses to define those areas which would be obstructed for all eye points on the Eyellipse. The area outside the collection of all the binocularly obstructed areas will be visible to the selected group represented by the Eyellipse.
- 6.3.2 **APPROXIMATING UNOBSTRUCTED AREAS**—A method for approximating areas on a display surface which are not obstructed by the steering wheel, hub, and spokes is given in Appendix D.
- 6.4 Obstructions in the Indirect Field**—The obstructed angles or obstructed areas within the indirect field are defined in the same manner as those within the direct field except that the sight lines are traced through the indirect vision device and the distance between the eye point and obstruction is measured along a sight line between them.
- 7. Notes**
- 7.1 **Marginal Indicia**—The change bar (I) located in the left margin is for the convenience of the user in locating areas where revisions have been made to the previous issue of the report. An (R) symbol to the left of the document title indicates a complete revision of the report.

## APPENDIX A

## DEVELOPING V AND P POINTS

**A.1** V and P points are developed to simplify measurement of direct or indirect field of view or obstruction angle. They are used to position eye points relative to the coordinate system rather than relative to the Eyellipse. The points are developed from the Eyellipse and should be used only in the specific situations for which they are developed.

**A.1.1 V Point (Vision Point)**—A vision point is a specific point on any plane tangent to an Eyellipse. For example, the points A, B, and C in Figure A1 where the planes are tangent to an Eyellipse could be considered V points. The points could be positioned relative to the coordinate system and angular measurements made without the Eyellipse.

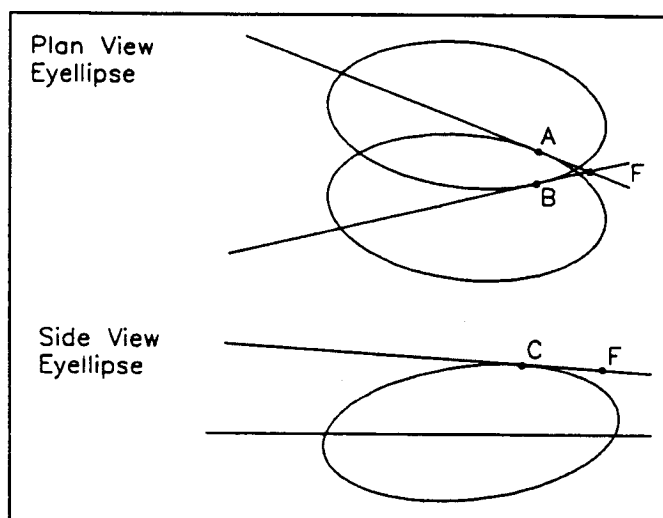

FIGURE A1—VISION (V) POINTS MAY BE DEFINED AT ANY POINT WHERE A PLANE IS TANGENT TO AN EYELLIPSE AS IN POINTS A, B, OR C, OR WHERE THESE PLANES INTERSECT AS IN POINT F

If the planes were extended rearward to where they all intersect at point F, a single V point at point F could be established which would enable the measuring of the angles left, right, and upward from one point. Although this simplifies the measurement by reducing the number of points, it also limits the range of angles that can be measured within an acceptable level of error. Only the angle used to define the V point will be tangent to the Eyellipse. All others will be inside or outside the Eyellipse. The resulting error must be weighed against the ease of use and acceptable limits determined.

**A.1.2 P Point (Neck Pivot Point)**—A P point is a specific neck pivot point positioned such that the eye points will fall on specific tangents to the Eyellipse. It is typically used in locating points closest to, or farthest from, a given location. For example, Point A in Figure 13 is the point on the Eyellipse farthest from point M. The neck pivot point is 98 mm rear of a point midway between point A and the corresponding point on the opposite Eyellipse. This neck pivot point could be defined as a P point and could be located without first locating the Eyellipse.

**SAE J1050 Revised JAN2003**

A.1.2.1 P POINTS DEFINED IN SAE J941—The four P points defined in SAE J941 were developed to be used for the measurements listed in A.1.2.1.1 to A.1.2.1.4.

A.1.2.1.1 *P1*—*P1* is used to measure the obstruction angle of an A-pillar to the left of the driver.

A.1.2.1.2 *P2*—*P2* is used to measure the obstruction angle of an A-pillar to the right of the driver.

A.1.2.1.3 *P3*—*P3* is used to measure the indirect field of view of rearview mirrors to the right of the driver.

A.1.2.1.4 *P4*—*P4* is used to measure the indirect field of view of rearview mirrors to the left of the driver.



APPENDIX B

APPROXIMATING THE INDIRECT FIELD OF VIEW USING "P" POINTS DEFINED IN SAE J941

- B.1** This method will approximate the largest horizontal and vertical indirect fields of view for the group of drivers defined by the 95% percent Eyellipse. It should be used only for the standard left- and right-hand passenger car mirror positions.
- B.1.1 Select the P Point**—If the rearview mirror is to the right of the driver, use neck pivot point P3. If the rearview mirror is to the left of the driver, use neck pivot point P4.
- B.1.2 Locate the Eye Points**—The eye points are 98 mm forward and 32.5 mm either side of the P Point.
- B.1.3 Rotate the Sight Line About the Eye Points**—Using the eye point farthest from any point on the mirror and the point on the mirror farthest from the eye point, rotate a sight line about the eye point until it either passes through the point on the mirror or reaches the angle allowed by maximum horizontal or vertical eye rotation. (See Figure 12)
- B.1.4 Rotate the Sight Line About the Neck Pivot Point (Figure 12)**—If the sight line from B.1.3 does not pass through the mirror point, rotate it about the neck pivot point until it does, but not farther than allowed by maximum head turn.
- B.1.5 Reflect Sight Lines From the Mirror Surface**—Reflect sight lines originating at the left and right eye points from points on the surface of the mirror.
- B.1.6 Define Field of View**—The field is defined using the horizontal and vertical angles of the sight lines or the points at which they intersect a target. The largest horizontal field will be found between the sight line from the left eye to the farthest right side of the mirror and the sight line from the right eye to the farthest left side of the mirror.

## APPENDIX C

## APPROXIMATING THE OBSTRUCTION ANGLE FROM A-PILLARS (FIGURE C1)

- C.1** Locate the eye points using one of the following methods.
- C.1.1** Locate the eye points relative to the appropriate neck pivot point. If the A-Pillar is to the left of the driver, use neck pivot point P1. If the A-Pillar is to the right of the driver, use neck pivot point P2.
- C.1.2** Locate one eye point at the point on the Eyellipse which is closest to a horizontal section through the A-pillar at the height of that point. Locate the corresponding eye point on the opposite Eyellipse. Locate the neck pivot point for these eye points.
- C.2** **Locate a Section Through the Pillar**—Determine a horizontal cross section of the A-Pillar at the height of the eye points.
- C.3** **Rotate the Sight Line About the Eye Point**—Rotate a sight line from the eye point closest to the obstruction until it is tangent to a point on the outboard side of the obstruction, but not farther than allowed by maximum eye movement.
- C.4** **Rotate the Sight Line About the Neck Pivot Point**—If the sight line of C.3 did not reach the obstruction, the eye points and sight line may be rotated about a vertical axis through the neck pivot point until the sight line reaches the outboard side of the obstruction but not farther than allowed by maximum head movement.
- C.5** **Define the Obstruction Angle**—The obstruction angle is defined as the angle between the line from the right eye to the right side of the obstruction and the line from the left eye to the left side of the obstruction. If these lines converge or are parallel, then no obstruction exists.

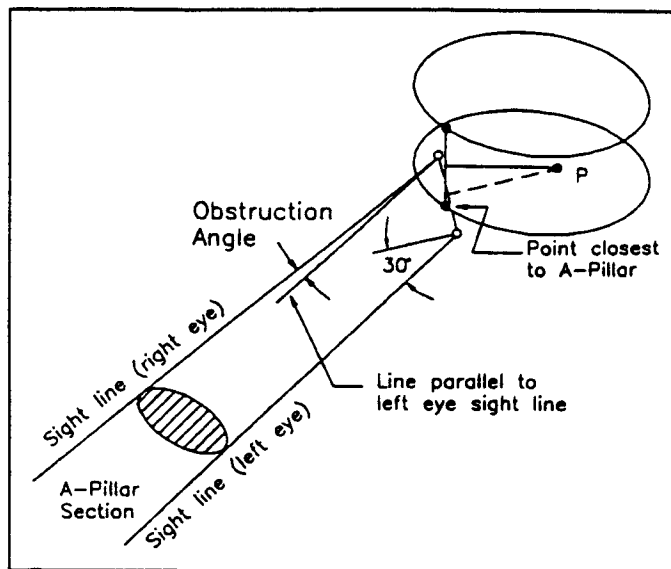

FIGURE C1—METHOD FOR DETERMINING A-PILLAR OBSTRUCTION ANGLE

## APPENDIX D

## APPROXIMATING THE VISIBLE AREAS ON CONTROL AND DISPLAY SURFACES

- D.1** This method will approximate those areas on control and display surfaces which will be visible to all drivers within a selected group. The selected group is determined by the Eyellipse chosen.
- D.1.1 Define the Geometry of the Display Surface of Interest as a Plane or Series of Planes**—These surfaces may be at the instrument panel or on stalks or other surfaces between the steering wheel and instrument panel.
- D.1.2 Define the Edges of the Top and Bottom of the Upper Half of the Steering Wheel Rim and the Upper Edge of the Hub and Spokes**—These may be defined as edges normal to sight lines from the mid-eye centroid (defined in SAE J941) or as edges in the plane parallel to the steering wheel face at the maximum section of the rim, spokes and hub.
- D.1.3 Defining Areas Obstructed by the Steering Wheel Rim**—In this method, the binocularly obstructed area caused by the steering wheel rim is established for a single set of eyes. This area is shifted on the display surface to approximate the obstructed areas which would be seen from other eye points on the Eyellipse. The area binocularly obstructed for anyone in the group is the collection of all the obstruction areas from all the eye points.
- D.1.3.1 DEFINE CHARACTERISTIC OBSTRUCTED AREA (FIGURE D1)**—Define the area on the display surface which is binocularly obstructed by the steering wheel rim using the left and right Eyellipse centroids as eye points. This area serves as the Characteristic Obstructed Area.

The monocular obstruction area on the display surface is a ring defined by the intersection points of sight lines tangent to the top and bottom of the steering wheel rim. The binocular obstruction area is that area which is obstructed for the left and right eye points simultaneously.

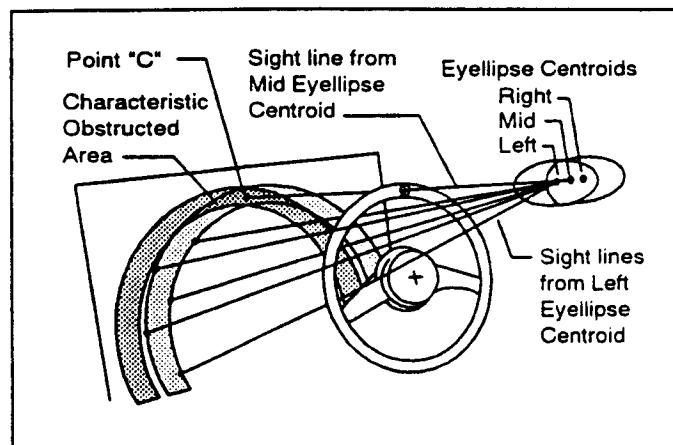

FIGURE D1—THE CHARACTERISTIC OBSTRUCTED AREA IS THE BINOCULARLY OBSTRUCTED AREA FOR THE LEFT AND RIGHT EYELLIPSE CENTROIDS. POINT 'C' IS FOUND USING A SIGHT LINE FROM THE MID-EYELLIPSE CENTROID THROUGH THE CENTER TOP OF THE STEERING WHEEL

D.1.3.2 DEFINE POINT "C" (FIGURE D1)—Define Point "C" within the Characteristic Obstructed Area where a sight line from the eye midway between the left and right centroids and through the center of the upper rim intersects the display surface.

D.1.3.3 DEFINE THE CLOSED CURVE ON THE DISPLAY SURFACE (FIGURE D2)—Define a closed curve using points on the display surface where sight lines which are tangent to the mid-Eyellipse and which go through the center of the steering wheel rim, intersect the display surface. In most cases, the closed curve will be an ellipse which can be drawn using the sight lines from the top, bottom, left, and right of the Eyellipse.

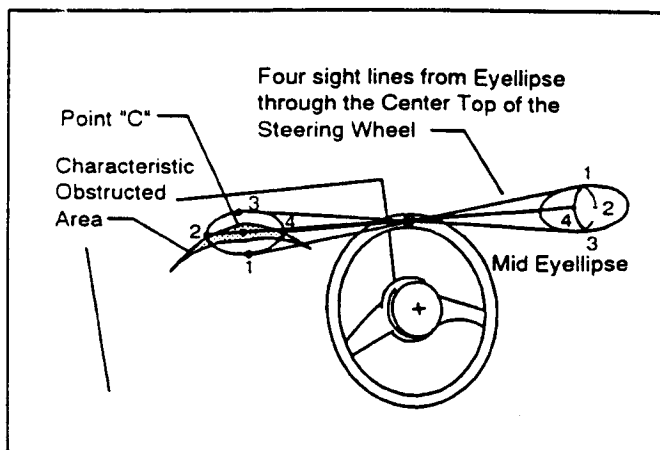

FIGURE D2—THE POINTS WHERE LINES TANGENT TO THE MID-EYELLIPSE AND THROUGH THE CENTER TOP OF THE STEERING WHEEL INTERSECT THE DISPLAY SURFACE DEFINE A CLOSED CURVE ON THE SURFACE

D.1.3.4 DEFINE BINOCULARLY OBSTRUCTED AREAS (FIGURE D3)—Locate the binocularly obstructed area for each point on the closed curve by shifting Point "C" and the Characteristic Obstructed Area along the closed curve. The binocular obstruction for each point on the curve is the projection of the Characteristic Obstruction Area onto the display surface at that point. The collection of all obstruction areas for all points along the curve defines the total area obstructed for the selected group of drivers.

#### D.1.4 Defining Areas Obstructed by the Steering Wheel Hub and Spokes (Figure D4)

D.1.4.1 LOCATE EYE POINTS—Locate left and right eye points at the points where sight lines through the center of the upper half of the steering wheel hub are tangent to the bottom of the left and right Eyellipses, respectively.

D.1.4.2 DEFINE MONOCULARLY OBSTRUCTED AREAS—For each eye point, locate points on the display surface where sight lines through points along the top of the hub or spokes intercept the display. The monocular obstruction area on the display surface is the area below these points. The binocular obstruction area is that area which is obstructed for both left and right eyes simultaneously.

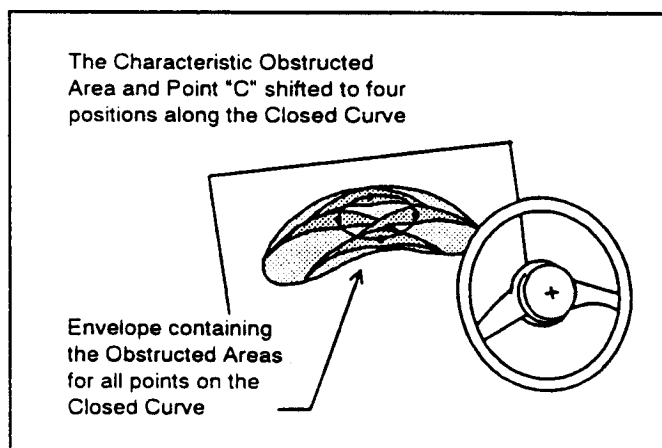

FIGURE D3—THE BINOCULAR OBSTRUCTION AREA FOR EACH POINT ON THE CURVE IS FOUND BY POSITIONING THE CHARACTERISTIC OBSTRUCTED AREA WITH POINT 'C' AT THE POINT ON THE CURVE. AN ENVELOPE CAN BE DEFINED THAT CONTAINS ALL THE OBSTRUCTIONS.

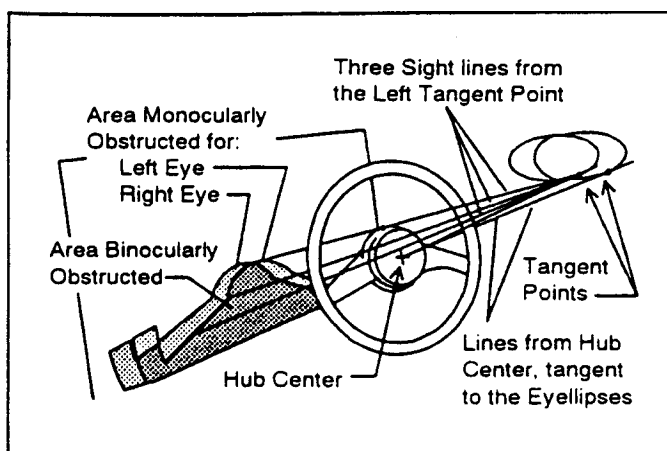

FIGURE D4—THE BINOCULAR OBSTRUCTION AREA DUE TO THE STEERING WHEEL HUB AND SPOKES IS FOUND USING AS EYE POINTS, THE POINTS WHERE LINES FROM THE CENTER OF THE HUB ARE TANGENT TO THE BOTTOM OF THE LEFT AND RIGHT EYELLIPSES

**D.1.5 Define the Unobstructed Areas**—The area outside those areas identified as being binocularly obstructed by the steering wheel in D.1.3.4 or by the hub and spokes in D.1.4.2 are visible to all drivers in the specified group. (Figure D5)

NOTE 1—The Eyellipse is based on a straight-ahead static viewing task. Any head movement to the left or right and up or down is easy to achieve and would reduce the extent of the binocularly obstructed areas.

NOTE 2—The binocularly obstructed areas defined represent a collection of all the areas which are binocularly obstructed to anyone within the selected group of drivers. In some cases, displays placed in these collected obstructed areas may be acceptably visible to individual drivers depending on size and location. The user should establish head movement limits as well as minimum portions of displays for acceptable visibility so as to not overly restrict design criteria developed from this practice.

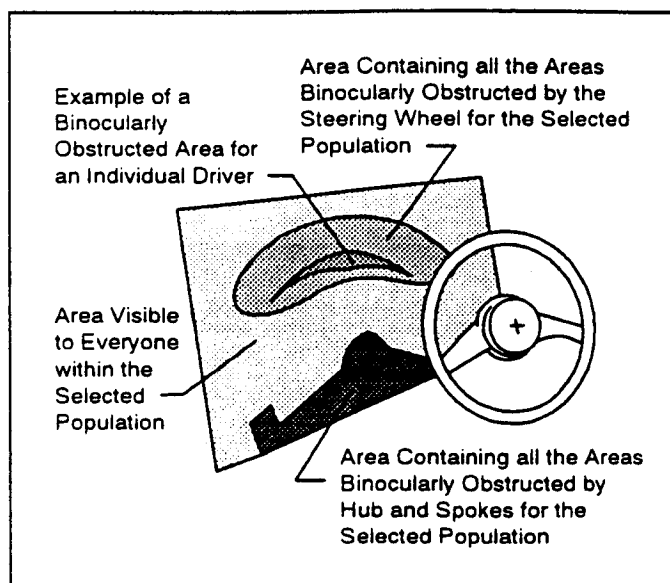

FIGURE D5—AREAS OUTSIDE THOSE WHICH CONTAIN ALL THE BINOCULARLY OBSTRUCTED AREAS ARE SEEN BY EVERYONE WITHIN THE SELECTED POPULATION

**D.2 Head Movement to Reveal an Obscured Display or Display Identification (Figure D6)**—It is highly desirable that no display or display identification is binocularly blocked from drivers when the steering wheel is in its design position. However, if a display or display identification is located in the binocularly obstructed area, as determined per D.1.5, head movement can reduce the extent of the obstruction.

**D.2.1 Range of Head Movement**—The range of head movement is defined so that a new reference eye point, from which to recalculate an area obstructed for a group of drivers, lies in the semicircle shown in Figure D6. The center of rotation of this semicircle is the cyclopean eyellipse centroid; the semicircular arc extends +90 degrees about a sight line extending forward from eyellipse centroid; the radius R, which defines the amount of head movement, is determined by the user. The user should not only establish limits for the amount of head movement, but also criteria for the portion of the display or display identification that must be visible.

**D.2.2 Construction Procedure**—The following procedure may be used to determine the amount of head movement needed to reveal a display or display identification:

- Construct the binocularly obstructed area (based on eyellipse centroid) per the procedure described in D.1.5.
- Measure the maximum movement, in the display plane, needed to reveal the obscured display or display identification.
- The amount of head movement, M, needed to reveal the obscured display or display identification can be approximated by Equation D1.

$$M = S \cdot (C/P) \quad (\text{Eq. D1})$$

where:

S = movement needed at the display plane to reveal the display or display identification.

C = distance from the eyellipse centroid to the upper rim center and,

P = distance from the upper rim center to the display plane.

- Select an eye point, in the semicircle shown in Figure D6, in a direction appropriate to reveal the obscured display or display identification.

- e. Using this new eye point, construct the binocularly obstructed area per the procedure described in D.1.5.
- f. The obstructed area with head movement is the obstructed area that is common to the obstructed areas from each eye point examined.

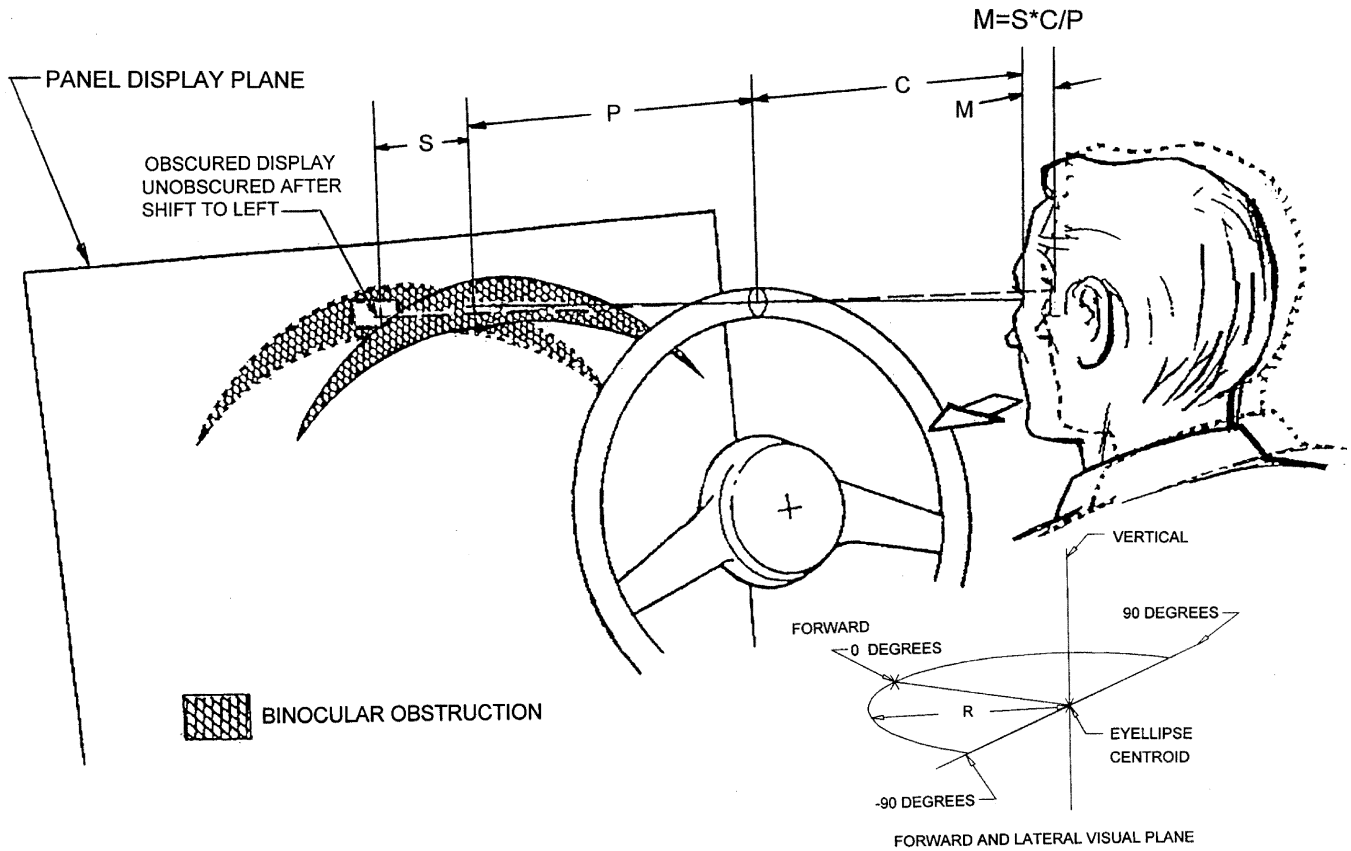

FIGURE D6—HEAD MOVEMENT TO REVEAL AN OBSCURED DISPLAY MOVEMENT SHOWN TO THE LEFT

## SAE J1050 Revised JAN2003

**Rationale**—SAE J1050 defines procedures for measuring the direct and indirect fields of view and the extent of obstructions in those fields. The basic method and procedures used in the current SAE J1050 are not altered by this recommended revision. Any procedures currently in place based on the current SAE J1050 need not be changed in light of the revisions. The revision was primarily to expand the use of SAE J1050 beyond a drafting procedure to take advantage of expanded capabilities available using computers and to improve the language to make it more user friendly.

The largest difference that will be noticed is in the general philosophy of the document. The current document was meant primarily as a drafting tool. It gives specific step-by-step procedures. The revised document is meant as a reference on measuring driver vision. Within each section, the document gives general measurement guidelines, followed by a section on how to measure the field for any individual driver and then a section on how to measure the limiting fields for a group of drivers. Several commonly used approximation methods have been included as appendices. The sections on fields for an individual driver are new. They offer a user the ability to define the total viewing environment for a single driver. The sections using the Eyellipse include an explanation of what fields determined using the Eyellipse represent.

The language of the document was also revised so that the user could better understand what was being done. This should help avoid misuse and allow him to apply the procedures to his specific needs. For example, where the current document read:

5.4.4 Rotate points B and C around point D in the plan view, until a sight E can be constructed from the relocated point B (point B') viewing point E on the upper right corner of the mirror reflective surface, with the sight line E

the new document reads:

5.1.3 Rotate the sight line within the limits of allowable head turn. (Figure 12) If the sight line from 5.1.2 does not pass through the display point, rotate it about the neck pivot point until it does ...

All figures were revised to improve clarity.

**Relationship of SAE Standard to ISO Standard**—Not applicable.

**Application**—This SAE Recommended Practice establishes methods for describing and measuring the driver's field of view. The document describes three methods for measuring the direct and indirect fields of view and the extent of obstructions within those fields. The first method uses any single pair of eye points to determine the fields or obstructions that would be seen by an individual driver. The second method uses the SAE Eyellipses defined in SAE J941 to determine the largest fields or obstructions that would be seen for a given percentage of the driving population. The third method uses specific eye points defined in SAE J941 to measure the extent of a specific field of view or obstruction for which those points were developed.

### Reference Section

SAE J264—Vision Glossary

SAE J941—Motor Vehicle Drivers' Eye Locations

SAE J985—Vision Factors Considerations in Rear View Mirror Design

**Developed by the SAE Driver Vision Standards Committee**